

EVALUATING INVESTMENT DEFERRAL BY INCORPORATING DISTRIBUTED GENERATION IN DISTRIBUTION NETWORK PLANNING

D. T-C. Wang
d.wang@ed.ac.uk

L. F. Ochoa
luis_ochoa@ieee.org

G. P. Harrison
gareth.harrison@ed.ac.uk

C. J. Dent
chris.dent@ed.ac.uk

A. R. Wallace
robin.wallace@ed.ac.uk

School of Engineering and Electronics, University of Edinburgh
Edinburgh, UK

Abstract—Environmental concerns, the need to diversify the energy mix, together with technology advances have made Distributed Generation (DG) increase worldwide over recent decades. One of the major and well-recognised benefits of DG is its ability to defer future demand-related investments, providing potentially significant savings and competitive advantage for regulated Distribution Network Operators (DNOs). In this paper an approach that considers the successive elimination method and multistage planning is proposed in order to quantify the investment deferral brought about by DG. Here, each required reinforcement and its implementation schedule affected by the connection of DG can be clearly identified by the DNO. A typical UK distribution network circuit is evaluated. Results show that characteristics of DG such as location, size, power factor and the commissioning time can result in significant reductions of the total planning costs. The investment deferral per MW of connected DG is also investigated as an index that could assist DNOs in evaluating the attractiveness of potential connection points as well as in quantifying the benefit produced by DG.

Keywords: *Distribution networks, distributed generation, investment deferral, planning*

1 INTRODUCTION

Driven by environmental and security concerns, governments around the world have set targets to diversify and decarbonise their energy mixes in the coming decades. It is therefore certain that renewable and combined heat and power (CHP) technologies will continue to have incentives to increase their connection to distribution networks.

Depending on its location, technology, penetration and robustness of the system, integration of Distributed Generation (DG) may bring about various challenges for Distribution Network Operators (DNOs), Transmission Network Operators (TNOs) and regulators [1, 2]. Potential benefits are also offered by DG. The UK's Renewable Obligation is a clear example of a scheme that recognises that renewable DG plays an important role in reducing carbon dioxide emissions. However, to establish proper market signals and therefore encourage DG developers it must be understood that other benefits brought about by these technologies should be assessed and quantified.

Since DG is accommodated in distribution networks relatively close to the load, it has the potential to alleviate network power flows. While power loss reduction is a direct technical benefit for the DNO, its economic impact will be only seen depending on the corresponding regulatory agency's strategy for improving DNO efficiency. Therefore, a tangible economic benefit for DNOs is that by decongesting network assets, DG has the ability to help avoid or defer reinforcements required by demand growth in a given horizon.

Investment risk in competitive power markets, approval for major investments required from the regulators, and cost-effectiveness of current DG technologies are among the main drivers for considering new generation in order to increase the capacity of the network [3]. Although this characteristic of DG has already been discussed by researchers and industry and UK DNOs are currently consulting on distribution charging methodologies that recognise the ability of DG to delay load-related investments [4, 5], research is ongoing to fully quantify it.

Brown *et al.* [6], proposed a successive elimination algorithm for distribution network expansion considering the specific siting of generation units. This simple planning technique makes it possible to calculate the investments required by the non-DG and DG scenarios, thus obtaining the corresponding monetary benefit. Mendez *et al.* [7] demonstrate the impact of different DG penetration and concentration levels and technology mixes on allowable load growth without the need for reinforcements. Gil and Joos [8] developed an approach based on the amount of network currents reduced by a DG unit, assuming that the reinforcement deferment was equivalent to the time required for the currents to reach the pre-DG level.

In this work, the deferment will be considered as that which occurs when investments that are required to enable further capacity are postponed as a result of connecting non-intermittent DG (e.g., CHP, CCGT). Moreover, given the multistage nature of network upgrades, i.e., investments are performed throughout the planning horizon, the impact of siting DG in different stages will be also analysed. The successive elimination planning method [6], by which the network is firstly overbuilt

with all possible reinforcement options, and a final solution obtained by successively eliminating the least cost-effective expansion option, will be adopted.

This paper is structured as follows: in Section 2 the methodology to be used for the investment deferral analyses is presented. A typical UK distribution network circuit is evaluated and results are discussed in Section 3. Security of supply-related opportunities for DG are investigated in Section 4. Section 5 discusses other issues related to DG. Finally, conclusions are drawn in Section 6.

2 METHODOLOGY

Mendez *et al.* [7] studied distribution investment deferral in terms of the load growth that certain penetrations and concentration levels of different DG technologies would allow the network to achieve without requiring further capacity upgrades. However, while the results clearly show the impact DG has on deferring investments, this study cannot be used for quantifying the relative benefit that a generation unit may bring about according to its location.

While the siting and sizing of DG units are not necessarily decided by DNOs, studies that supply information regarding the most beneficial connections points and generation capacities – from the network point of view – might be used to create a framework for incentives or charging schemes. Following this idea, in [8], the capacity deferral benefit of a single DG unit was calculated for every node of a distribution network. Whilst this approach provides the relative benefit of DG in monetary units per connected kVA, the adopted deferral time was not appropriate since it considered the time required for the network power flows to return to the level prior to the connection of DG (see Appendix). The economic benefits of DG are quantified more accurately if the deferment is relative to the time when the reinforcement costs are incurred.

In order to evaluate the effect that the placement of generation units may have on the expansion planning costs, the reinforcements required by the original (non-DG) and DG scenarios need to be determined. For this purpose, a two-phase approach is adopted for a given case of load growth, planning horizon, and presence or absence of new DG. Firstly, the Successive Elimination (SE) method is carried out in order to evaluate the capacity upgrades needed by the distribution network. Secondly, the multistage planning analysis is performed, by which the required investments are scheduled according to the needs of the network. Finally, the total expansion planning costs are calculated for the studied case. The difference between the costs required for the original scenario and the DG scenarios will correspond to the value of investment deferral produced by the connection of new generation.

The following subsections describe in detail each phase of the proposed methodology.

2.1 Successive Elimination Method

The successive elimination method presented in [6] is adopted to determine the most cost-effective network expansion combinations at the end of the planning horizon. Metaheuristic optimization planning strategies for distribution networks commonly found in the literature (e.g., Genetic Algorithms, Simulated Annealing or Tabu Search) are likely to give a better solution than so-called greedy heuristics like SE. However, the latter will still produce a reasonable solution with little computational effort due to its simplicity of implementation. Additionally, the methodology is straightforward which makes the process easily understandable by the planner due to the use of a cost-effectiveness index.

The fundamental concept of the SE method is to initially overbuild the network with all reinforcement candidates including transformers and lines. Then, the least cost-effective option is removed until the further removal of any remaining candidate would cause system constraint violations during the planning horizon. Figure 1 shows the flow chart for the SE technique.

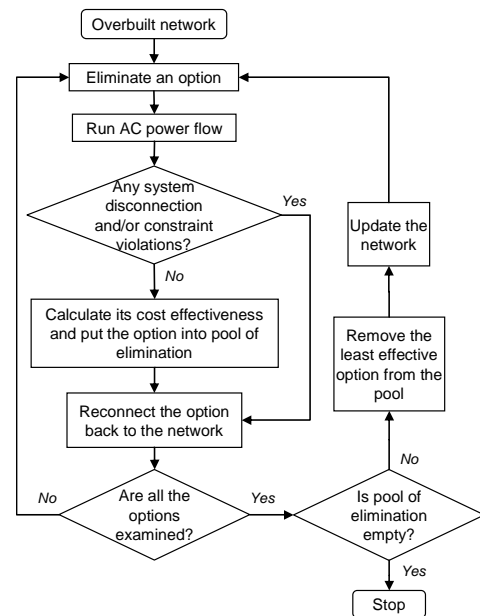

Figure 1: Flow chart of the Successive Elimination Method.

The steps of the methodology are as follows:

- Step 1.** Consider the load demands corresponding to the year at the end of the planning horizon.
- Step 2.** Identify all the required network capacity expansion options and connect them to the network. Verify that the overbuilt network has no constraint violations (thermal and voltage).
- Step 3.** Disconnect each expansion candidate in turn and verify constraints are being fulfilled and loads are being supplied. If so, calculate its cost-effectiveness using the following equation:

$$CE_a = \frac{P - P_a}{Cost_a} \quad (1)$$

where CE_a is the cost-effectiveness measurement of option a in MW/\$, P is the sum of the real power flows through all lines and transformers for the current dummy network, P_a is the sum of real power flows through all lines and transformers of the network without option a ; and, $Cost_a$ is the cost of option a . Since the formulation of cost-effectiveness is based on the reserve capacity provided by eliminating planning options, then the lower values will correspond to the least cost-effective investments.

The candidate is then put into an elimination list. Repeat Step 3 until all expansion candidates have been examined.

Step 4. Compare the cost-effectiveness of all the options in the elimination list. Find out the least cost-effective candidate and remove it from the network. If the list is not empty, go to Step 3, otherwise go to Step 5.

Step 5. The final expansion plan has been determined. Save the remaining candidates for the multi-stage planning analysis.

2.2 Multistage Planning Analysis

The purpose of the multistage planning analysis is to schedule the implementation of the reinforcements obtained from the SE method along the planning horizon. Thus, by scheduling the reinforcements according to the demand growth it is possible to evaluate the investment deferral produced by the connection of DG at different stages. Figure 2 shows the flow chart for the multistage planning.

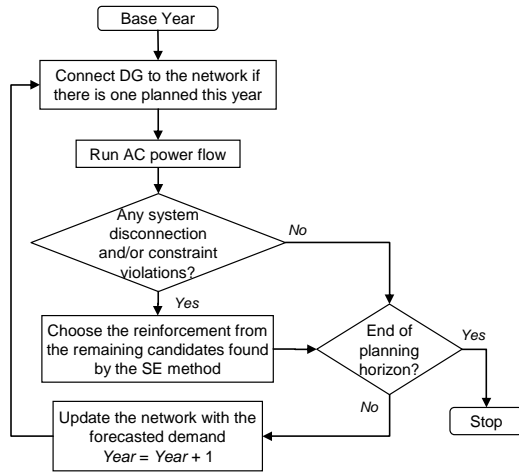

Figure 2: Flow chart of the Multistage Planning.

The steps of the procedure are as follows:

Step 1. Forecast the demand for the base year.

Step 2. Connect any scheduled DG.

Step 3. Verify whether there are system disconnections or constraint violations. If not, go to Step 4, otherwise choose the most cost-effective reinforcement from the remaining candidates found

by the SE method. If required, capacitors can also be placed.

Step 4. Stop if the planning horizon has been achieved. Otherwise, forecast the demand for the next year and return to Step 2.

2.3 Investment Deferral

From the previous two subsections, the capacity upgrades for the network expansion and the corresponding scheduling of investments can be determined. To obtain the total investment incurred by each planning scenario studied, the present value of each upgraded asset should be calculated. In this way, the total present value (PV) cost of the plan is given by:

$$PV = \sum_{t=1}^h \sum_{i=1}^n \frac{C_{i,t}}{e^{\rho t}} \quad (2)$$

where h is the number of years in the planning horizon, n is the number of reinforcements required for year t , C_i is the cost of asset i required for year t , and ρ is the continuously compounded annual discount (or interest) rate.

The investment deferral, as a benefit brought about by the connection of new DG, is then calculated by subtracting the PV of the total investment required by a given DG planning scenario from that of the original (no new generation) planning scenario:

$$Inv. Deferral = \sum_{t=1}^h \sum_{i=1}^n \frac{C_{i,t}}{e^{\rho t}} \Big|_{no\ DG} - \sum_{t=1}^h \sum_{i=1}^n \frac{C_{i,t}}{e^{\rho t}} \Big|_{DG} \quad (3)$$

3 APPLICATIONS

The methodology is applied to a 20-bus distribution network. First, the traditional planning analysis, i.e., excluding DG, is applied to the test network. Then, in order to evaluate the locational deferral benefit throughout the circuit, a single DG unit is placed at each load node in turn. Finally, the investment deferral when DG is connected at different stages of the planning horizon (15 years) is studied. A load growth of 2% and a real discount rate of 6% were adopted. Voltage limits were set to $\pm 6\%$ of the nominal voltage. The generation capacities analysed here will be small relative to the load, therefore, DG-led reinforcements will not be considered in the planning costs.

The successive elimination method and multistage planning analysis were implemented in the commercially available PSS/E power systems modelling environment using the Python programming interface.

3.1 Traditional Planning Analysis

The 20-bus test network, as depicted in Figure 3, is a simplified circuit from the United Kingdom Generic Distribution System – EHV Network 6 [9]. The network topology is highly radial while the major branches are supplied by the 275kV grid point via 275kV/132kV transformers. Energy is delivered through 132kV lines and stepped down to 33kV when entering the major load zones with high customer density. All loads are connected at 11kV and total 173.4 MW.

Applying the successive elimination method and the corresponding multistage analysis without considering any new generation, Table 1 presents the scheduling of the investments required along the 15-year planning horizon. The present value of the total planning investment accounts for approximately US\$ 1.91 million.

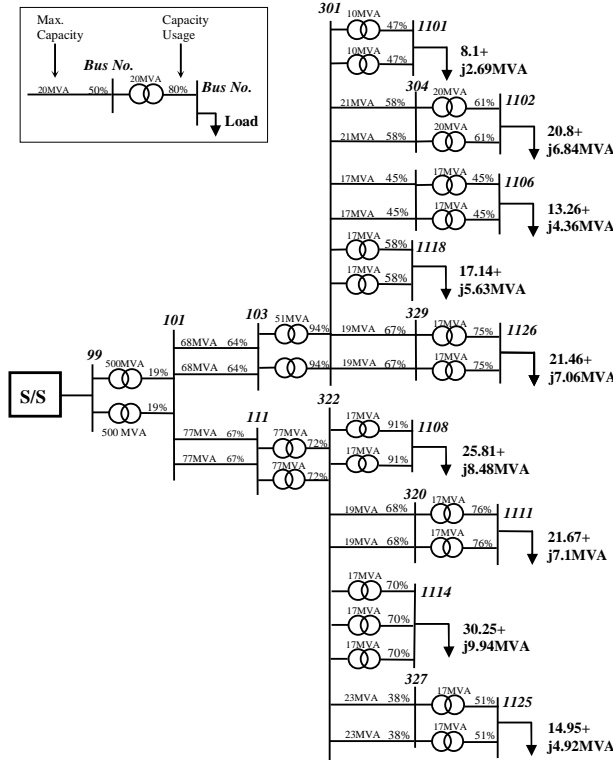

Figure 3: Simplified 20-bus network from the United Kingdom Generic Distribution System [9].

Location	Feeder	Capacity (MVA)	Cost (10 ³ US\$)	Year of Execution	Present Value (10 ³ US\$)
103-301	103	1 x 68	1212	3	1012.10
322-1108	111	1 x 23	248	5	183.80
320-1111	111	1 x 23	248	13	113.74
329-1126	103	1 x 23	248	14	107.11
111-322	111	1 x 68	1212	15	492.64
Total Investment Required					1909.39

Table 1: Scheduling of new transformers required along a 15-year planning horizon, without considering DG connection.

From Figure 3 it can be seen that the capacity usage of the lines is relatively low compared to that of the transformers. Indeed, given the initial characteristics of the network assets, the 132.33kV transformers located at 103-301 (2x51MVA; 6% capacity headroom) need to be upgraded sooner than those at 111-322 (2x77MVA; 28% headroom). Also due to the capacity usage, reinforcements are also required for those transformers corresponding to the loads at 1108, 1111, 1126, which are the 2nd, 3rd and 4th largest loads of the systems. The most heavily loaded bus (1114) is served by three trans-

formers (3x17MVA) guaranteeing enough spare capacity. No line needs reinforcement.

3.2 DG Analysis – Base Year Connection

The initial analysis considered the connection of a single generator (unity power factor) at the 11kV bus 1126 commissioned in the base year, i.e., at the beginning of the planning horizon. By applying the methodology presented in the previous section it is possible to compute the new total investment required and the corresponding scheduling of new equipment for different capacities of DG.

Results shown in Table 2 clearly indicate the impact of the generator on displacing the need for further network capacity, creating a new scheduling for those transformers required for the non-DG planning scenario (Table 1) and, therefore, deferring the investment. Although the costs of the DG connection and consequent network upgrades were not considered in the analysis, the costs related to those reinforcements displaced over the 15-year horizon were still assigned to the total present value in order not to overstate the benefit brought about by DG.

It can be verified that while the schedule of those transformers located in the feeder below bus 103 (in bold) was affected, the connection of the DG had no influence on the capacity upgrades required for the feeder below bus 111. Moreover, in this particular case, it can be seen that the larger the power output, the larger the investment deferral.

Year of Execution	no DG	DG Capacity (MW)					
		1	2-3	4-5	6-7	8-9	10
3	103-301	103-301					
4			103-301				
5	322-1108	322-1108	322-1108	103-301	322-1108	322-1108	322-1108
6					103-301		
7						103-301	
8							103-301
13	320-1111	320-1111	320-1111	320-1111	320-1111	320-1111	320-1111
14	329-1126						
15	111-322	111-322	111-322	111-322	111-322	111-322	111-322
>15			329-1126	329-1126	329-1126	329-1126	329-1126
Present Value (US\$)	1909.39	1903.15	1838.34	1782.83	1730.55	1681.32	1634.96
Investment Deferral		0.33%	3.72%	6.63%	9.37%	11.94%	14.37%

Table 2: Scheduling of new transformers required along a 15-year planning horizon with various DG capacities connected at bus 1126.

The same analysis was applied to each of the load buses in turn. The planning investments required for the planning horizon were calculated for different capacities at unity power factor. Figure 4 shows the investment deferred as a percentage of the total expansion cost without DG (Table 1), for the most and least sensitive buses for each of the two main feeders.

Due to the high cost of a new transformer at 103-301 and, given the need for its near-term replacement, placing a generator with significant capacity at any of its downstream load buses results in larger savings than

siting the DG unit within feeder 111. However, as illustrated in Figure 4, within the same feeder the location of the generator also influences its ability to defer investments. Since it is the headroom of the transformers upstream from the loads that also determines how soon reinforcements will be needed, proper siting of DG is able to bring about the largest benefits. Consequently, the larger the penetration of DG does not necessarily mean a larger investment deferral benefit.

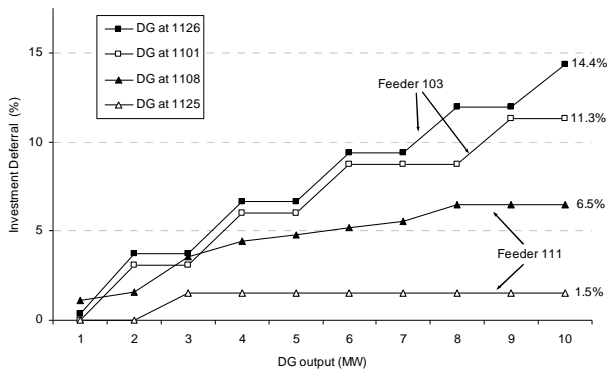

Figure 4: Investment deferral benefit with single DG unit of different capacity at several locations.

Another parameter that influences how the DG connection impacts on the total expansion cost is its power factor. Figure 5 shows the results corresponding to the connection of a DG unit at bus 1126, varying its power output and considering 0.9 lagging (injecting reactive power), unity and 0.9 leading (absorbing reactive power) power factors. As expected, the lagging power factor scenario improves the network voltage profile, increasing also the capacity headroom, and therefore postponing investments. On the other hand, leading power factor forces earlier circuit reinforcement and, above a capacity of 7MW, the need for capacitors to support feeder voltage.

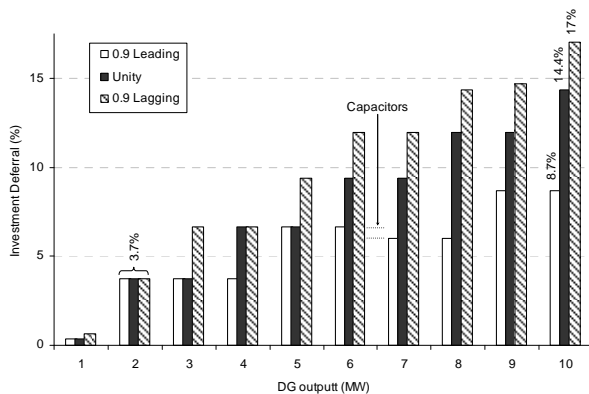

Figure 5: Investment deferral benefit of different DG capacities and power factors at bus 1126.

By analysing the DG impact on the total expansion planning cost, as shown in Figure 4 and Figure 5, it is possible to obtain the average investment deferral per MW of a single DG unit connected to each of the stud-

ied load buses. These values are shown in Figure 6. As expected, siting a generator at bus 1126 leads to the largest benefits per MW, suggesting that, from the DNO point of view, a DG of any size would be better located there than at any other point of the network in order to defer the most investment. It can also be verified, as observed previously in Figure 5, that larger benefits are achieved when a lagging power factor is adopted by the generator.

While Figure 4 is useful in identifying the investment deferral trends with DG capacity, it is with Figure 6 that a better comparison of the benefits brought about per MW of DG can be made. Indeed, the results of such an analysis could be used to help create a charging methodology that considers the benefit of DG on investment deferral.

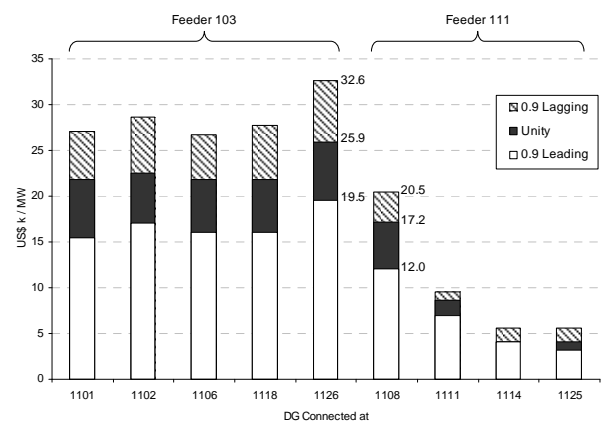

Figure 6: Investment deferral per MW of a single DG unit.

3.3 DG Analysis – Scheduling Connection

In the previous subsection the commissioning of the DG unit was considered to take place at the base year of the planning horizon. As the proposed methodology highlights the scheduling of the required investments, the effect of different commissioning times can be evaluated.

Table 3 presents the investment deferrals produced by connecting a 5MW generator (unity power factor) at bus 1126, considering three different commissioning times: base year, year 3 and year 4. The load growth requires the feeder 103 to be reinforced at year 3 with the installation of an extra 68MVA transformer (non-DG case, Table 1). Therefore, the placement of a DG unit during that period will reduce the local load, alleviating the power transfer and deferring part of the investment. On the other hand, Table 3 shows that commissioning the generator at year 4 will only delay the installation of the 23MVA transformer (329-1126) directly upstream from the DG, resulting in fewer savings.

The effect of two 5 MW, unity power factor, DG units located at buses 1126 and 1108, which presented the largest sensitivities for each feeder (Figure 4 and Figure 6) are shown in Table 4. The investment deferral benefit of both generators was found to equal the sum of

their individual benefits (Figure 4). This is explained by the fact that DG sited in one feeder does not affect the loads or the planning process of the other (although protection schemes in neighbouring feeders might need to be reinforced; this scenario was not considered). Additionally, the effect on the investment deferral produced by the late commissioning of the generators can also be verified in this case.

Year of Execution	no DG	Commissioning of DG at bus 1126 (Year)		
		0	3	4
3	103-301			103-301
5	322-1108	103-301	103-301	322-1108
13	320-1111	322-1108	322-1108	320-1111
14	329-1126	320-1111	320-1111	320-1111
15	111-322	111-322	111-322	111-322
>15		329-1126	329-1126	329-1126
Present Value (US\$)	1909.39	1782.83	1782.83	1897.28
Investment Deferral		6.63%	6.63%	0.63%

Table 3: Scheduling of new transformers required with different commissioning times for a 5MW DG at bus 1126.

Year of Execution	no DG	Commissioning of DG at buses 1126 & 1108 (Year & Year)		
		0 & 0	3 & 5	4 & 6
3	103-301			103-301
5	322-1108	103-301	103-301	322-1108
12		322-1108	322-1108	
13	320-1111	320-1111	320-1111	320-1111
14	329-1126			
15	111-322			
>15		111-322	111-322	111-322
		329-1126	329-1126	329-1126
Present Value (US\$)	1909.39	1691.10	1691.10	1868.59
Investment Deferral		11.43%	11.43%	2.14%

Table 4: Scheduling of new transformers required with different commissioning times for two 5MW DG connected at buses 1126 and 1108.

Here, the results obtained are similar to those from the elementary analysis in the Appendix. However, the necessary upgrades are not obvious in meshed networks where changing the impedance of a line changes flow patterns in the network. This is also the case in any network (meshed or radial) where voltage constraints are important or where a wider range of upgrades such as VAR support is available.

4 SECURITY OF SUPPLY

In the cases above, only the reinforcements related to network capacity were considered. However, reinforcements related to the security of the supply can be also incorporated into the proposed methodology without significant modifications. Assuming a scenario where DG is allowed to contribute to the security of supply of the network – as it is in the UK – the approach would be able to quantify the impacts of DG on security-related investments.

Considering the UK Engineering Recommendation P2/6 [10], the following example shows how DG could contribute to avoid reinforcements required by security of supply standards.

4.1 Example

Figure 7 presents a two-bus test system that include two identical non-intermittent generators, each with declared net capacity of 20MW and 90% unit availability; both connected to a bus with a 60MW load. The load is connected to two 45MVA, 0.95 power factor transformers with 1.3 cyclic rating factor¹.

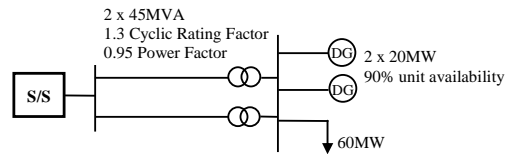

Figure 7: Two-bus test system.

Since the load is 60MW, only the first circuit outage (FCO) needs to be considered.

Without DG, the maximum amount of load that can be supplied following the outage of the most crucial circuit, i.e. the Network Capability (NC), would be:

$$NC \text{ after FCO} = 1 \times 45 \times 1.3 \times 0.95 = 55.6 \text{ MW} .$$

ER P2/6 provides lookup tables to search for the capability of DG as a function of DG availability and number of units [11]. In this case, the F factor for the two generation units with 90% availability is equal to 69%. Therefore, the two units connected to the load bus would have an effective contribution of generation equal to:

$$DG \text{ Contribution} = 0.69 \times 2 \times 20 = 27.6 \text{ MW} .$$

Then, this value can be added to the NC to meet the demand after the FCO, achieving a total of 83.2MW, allowing the circuit to fulfil the security of supply requirements without needing further investments.

Based on ER P2/6, an additional constraint regarding the maximum load allowed at each bus could be measured and considered in the proposed methodology in order to determine the security-related reinforcements and the consequent investment deferral when taking into account the connection of DG.

5 DISCUSSION

It is certain that location of CHP schemes will solely depend on the site where the existing plant is. Even for brand new industrial plants, the placing mainly relies on land availability. CCGT schemes also face the same limitations. As for renewables, on top of land issues, good source availability is also a major concern for the economic feasibility of a development.

While it is arguable that the connection point to the grid of new generation could be driven by locational

¹ More details on the ER P2/6 methodology in [10, 11].

prices, it is important to acknowledge all of the benefits brought about by DG in order to have proper market signals. Moreover, in a context where DNOs are allowed to invest in generation capacity, DG's ability to defer network upgrades might prove to be a profitable option.

Availability or load factor of non-intermittent generation may be also used to consider the actual DG capacity. Dealing with intermittent generation, such as wind power, is a more complex task. A typical load factor of wind farms might be applied to the capacity of a non-intermittent generation analysis. Nonetheless, a more suitable approach would be to include in the proposed methodology a time-series (e.g. hourly) or scenario-based analyses of both generation and demand.

6 CONCLUSIONS

An approach for quantifying the impacts that DG may have on the deferment of demand-related network reinforcements was developed, taking into account the effects of the generator's capacity, location and commissioning time. A successive elimination technique along with a multistage planning analysis was adopted in order to determine the required investments and their corresponding scheduling. Knowledge of the required assets and their commissioning time along the planning horizon enables identification of those assets affected by the connection of DG, making it possible to obtain the corresponding new total investment cost. DG-led reinforcements were not considered in the analysis due to the relatively small DG penetration studied, however a procedure to take into account such investments can be incorporated to the proposed methodology.

Results showed that the investment deferral varies significantly with the location, size and even the control strategy (power factor) of the generator. Furthermore, the calculation of the investment deferral per MW of DG appears to be a useful index for DNOs to identify the connection points that are most beneficial, recognising at the same time the extra value of DG. Such parameters could be used to incentivise DG developers at certain locations by adapting connection charging methodologies.

DNOs are usually not able to neither own generation nor decide the commissioning time of new developments. However, the second analysis clearly shows the impact that DG have when considered as an option in the planning process in order to defer demand-related investments. While regulations are unlikely to change in certain countries and uncertainties surround the actual commissioning of new developments, it would be of great value for DNOs to incorporate DG into the planning process.

ACKNOWLEDGEMENT

This work is partly funded through the EPSRC SuperGen V, UK Energy Infrastructure (AMPerES) grant in collaboration with UK electricity network operators working under Ofgem's Innovation Funding Incentive

scheme. Full details on <http://www.supergen-amperes.org>.

APPENDIX

Consider the two-bus example shown in Figure 8. According to [8], the connection of a 10MW generator at bus 2 would yield a reinforcement deferral corresponding to the time required for the load to achieve its base-year capacity needs, i.e. the time for the demand to increase from 20MW to 30MW.

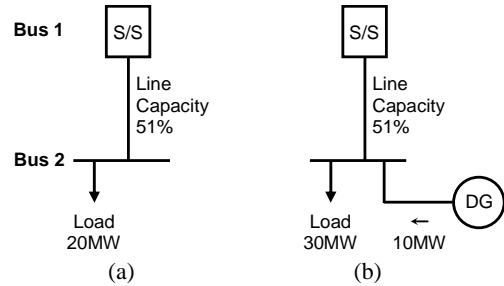

Figure 8: Two-bus test system (a) Base year, no DG; (b) Load increase required to achieve the non-DG line capacity.

Adopting an annual load growth of 3%, this time would be calculated as follows:

$$Time Def. = \frac{\ln\left(\frac{Load^f}{Load^0}\right)}{\ln(1+i)} = \frac{\ln\left(\frac{30}{20}\right)}{\ln(1+0.03)} = 13.7 \text{ years.}$$

where $Load^f$ is the future demand, $Load^0$ is the present demand and i is the annual load growth. However, as discussed previously, the time deferral must be based on the time the reinforcements are needed, in this case, when the maximum capacity of the line is achieved. As shown in Figure 9a, for the base year with no DG, the current will reach the line's rating when the load is 39.2 MW, while if DG is connected the reinforcement is only needed when the load increases to 49.2MW (Figure 9b). Therefore, the difference between the times required for the demand to achieve both cases corresponds to a time deferral of:

$$Time Def. = \frac{\ln\left(\frac{49.2}{20}\right)}{\ln(1+0.03)} - \frac{\ln\left(\frac{39.2}{20}\right)}{\ln(1+0.03)} = 7.7 \text{ years.}$$

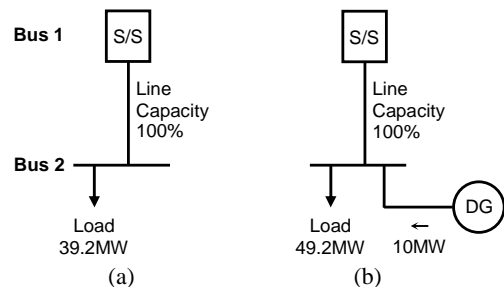

Figure 9: Two-bus test system using maximum line capacity (a) Load scenario without DG; (b) Load scenario with DG.

Consequently, the analysis based on the time required for the currents to reach the pre-DG level will lead to inaccurate results (in this case tends to overestimate the benefit), apart from the fact that does not take into account the problem of capacity reinforcements.

REFERENCES

- [1] P. P. Barker and R. W. d. Mello, "Determining the impact of distributed generation on power systems: part 1 - radial distribution systems," in *Proc. 2000 IEEE Power Engineering Society Summer Meeting*, pp. 1645-1656.
- [2] N. Jenkins, R. Allan, P. Crossley, D. Kirschen, and G. Strbac, *Embedded generation*. London: Institution of Electrical Engineers, 2000.
- [3] R. C. Dugan, T. E. McDermott, and G. J. Ball, "Planning for distributed generation," *IEEE Industry Applications Magazine*, vol. 7, no. 2, pp. 80-88, Mar.-Apr. 2001.
- [4] Scottish Power Energy Networks, Scottish and Southern Energy Power Distribution & E.ON Central Networks. (2007, Sept.). Structure of electricity distribution charges - Joint consultation on the longer term charging framework. [Online]. Available: http://www.energynetworks.org/spring/regulation/pdfs/DCMF/Consultations/G3consultation_070521.pdf
- [5] EDF Energy Networks. (2007, Sept.). Initial consultation on the principles behind EDF Energy Networks' enduring distribution use of system charging methodology. [Online]. Available: <http://www.edfenergy.com/hold/regulatory/downloads/edfenergynetworks-consult-uos-chargingmethod-no2.pdf>
- [6] R. E. Brown, X. F. J. Pan, and K. Koutlev, "Siting distributed generation to defer T&D expansion," in *Proc. 2001 IEEE PES Transmission and Distribution Conference and Exposition*, vol. 2, pp. 622-627.
- [7] V. H. Méndez Quezada, J. Rivier Abbad, J. I. de la Fuente, T. Gómez San Román, J. Arceluz, J. Marín, and A. Madurga, "Impact of distributed generation on distribution investment deferral," *International Journal of Electrical Power & Energy Systems*, vol. 28, no. 4, pp. 244-252, May 2006.
- [8] H. A. Gil and G. Joos, "On the quantification of the network capacity deferral value of distributed generation," *IEEE Trans. on Power Systems*, vol. 21, no. 4, pp. 1592-1599, Nov. 2006.
- [9] Distributed Generation and Sustainable Electrical Energy Centre. (2007, Oct.). United Kingdom Generic Distribution System. [Online]. Available: <http://www.sedg.ac.uk/>
- [10] Energy Networks Association, "Engineering Recommendation P2/6 - Security of Supply," July 2006.
- [11] R. Allan, G. Strbac, P. Djapic, and K. Jarrett, "Developing the P2/6 methodology," *Department of Trade and Industry (DTI)*, Apr. 2004.